



### Specifications

Item	- 35695A
Model	- LED Emergency Light - Square
Input Wattage	- 1.2 WATT Per Head
Input Voltage	- 120/277VAC
Listings	- UL Listed
Dimmable	- No
Height	- 4.5 inches (114mm)
Width	- 4.0 inches (102mm)
Length	- 12.1 inches (307mm)
Ambient operating temp.	- 32°F to 104°F (0°C to 40°C)
Housing	- Thermoplastic
Battery	- Ni-CD 3.6V 1000MAH
Installation Type	- Wall or Ceiling
Battery Life	- ≥ 90 minutes

### Caution

- Do not use outdoors
- Equipment should be mounted in locations and at heights where it will not be subject to tampering by unauthorized personnel.
- Do not mount near gas or electric heaters
- The use of accessory equipment that is not recommended by the manufacturer may cause an unsafe condition.
- Do not use this equipment for other than its intended use.
- Installation and servicing of this equipment should be performed by qualified personnel.
- Disconnect AC power before servicing
- Use caution when servicing batteries. Battery acid can cause burn to skin or eyes, If acid is spilled on skin or eyes flush acid with fresh water and contact a physician immediately.
- Suitable for indoor dry/damp locations

### Precaución

- No usar al aire libre.
- El equipo debe montarse en ubicaciones y alturas donde no estará sujeto a manipulación por personas no autorizadas personal.
- No lo monte cerca de calentadores de gas o eléctricos.
- El uso de equipos accesorios que no se recomiendan por el fabricante puede causar una condición insegura
- No use este equipo para otro uso que no sea el previsto.
- La instalación y el mantenimiento de este equipo deben ser realizados por personal calificado.
- Desconecte la alimentación de CA antes de realizar el mantenimiento.
- Tenga precaución cuando repare las baterías. El ácido de la batería puede causar quemaduras a la piel u ojos, si se derrama ácido sobre la piel o los ojos, enjuague el ácido con agua y contacte a un médico inmediatamente.



## NOTICE

The battery in this unit may not be fully charged after electricity is connected to the unit. Let the battery charge for at least 24 hours.

Unused wires must be capped using enclosed wire nuts.

During an electrical outage the lamps will automatically come on for a minimum of 90 minutes.

To test, press the "TEST" switch. The emergency lamps will illuminate. When the switch is released the lamps will turn off.

All wiring must be done in accordance to National Electrical Code (NEC) and local codes. Proper grounding is required to ensure personal safety. Carefully observe grounding procedure under the installation section.

## J-Box Installation

1. Feed the fixture through the back plate and connect to AC power supply. (Figure A) For 120V use black and white wires. For 277V use red and white wires.
2. Attach back plate to J-Box and secure with wires.
3. Complete the battery connection.
4. Align snaps and push housing directly onto the back plate (Figure C). Applies continuous AC power and press "TEST" button to check light.

## Conduit Installation

1. Secure back plate to wall surface. Route wires through hole in conduit flange and make conduit connection. For 120V, use black and white wires. For 277V, use red and white wires.
2. Complete the battery connection (Figure B).
3. Align snaps and push housing directly onto the back plate (Figure C). Apply continuous AC power and press "TEST" button to check light.

## Wiring Diagram

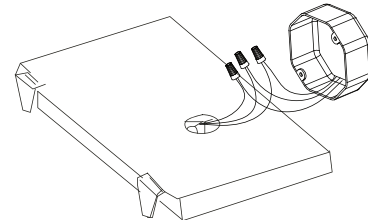
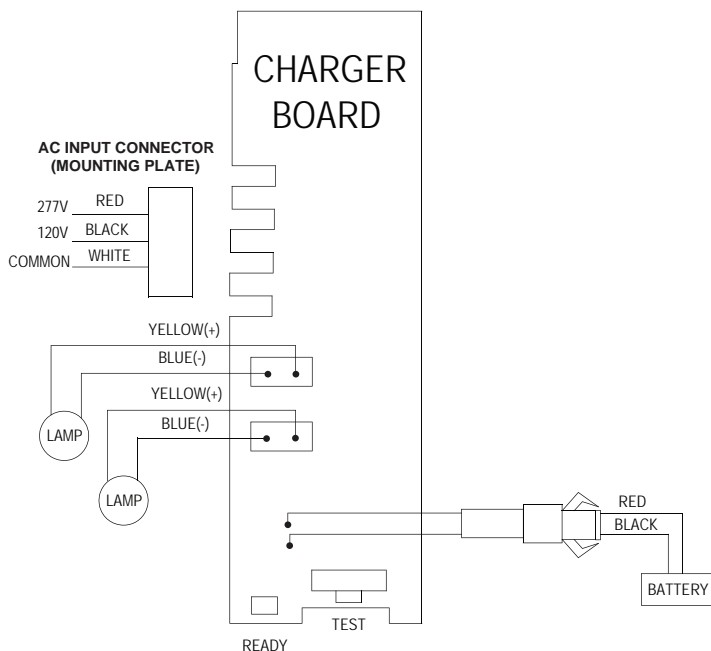

Fig.A (J-Box)

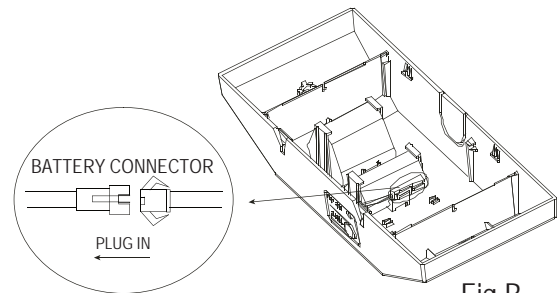

Fig.B

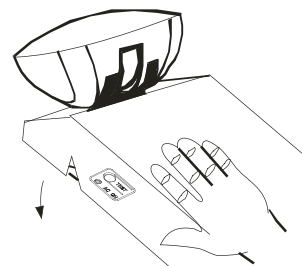

Fig.C