

### Specifications



- Item - 37122C
- Model - EMERGENCY DRIVER FOR TROFFER(37121A/37122A)
- Input Voltage - 120-277VAC 50/60Hz
- Output Voltage - 11-56VDC
- Power - 8W
- Recharge Time - 24 Hours
- Discharge Time - ≥90 minutes
- Ambient Operating Temp - 32°F to 122°F (0°C to 50°C)
- Battery Type - LiFePO4/9.6V/1500mAH

### Dimensions

**Emergency LED Driver:**  
Length - 5.89" (149.6mm)  
Width - 1.72" (43.6mm)  
Height - 1.00" (25.4mm)

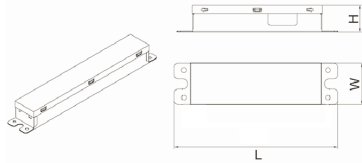

**Emergency LED Battery:**  
Length - 9.45" (240.0mm)  
Width - 1.10" (27.9mm)  
Height - 0.84" (21.3mm)

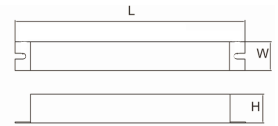

### Function

**SELF-TESTING:**

Please turn off the main power every 3 months, so as to let the battery operate a charging/discharging cycle. This will help the battery maintain a longer lifespan.

Please check the emergency function with the push test button.

**NOTES:**

Sealed unit. The battery is not replaceable, replace the entire unit when necessary.

**TEST Switch:**

Emergency conversion kit will go into emergency mode if test switch is pressed when main supply is on, it will go into charging mode if test switch is not pressed.

### Program Switch

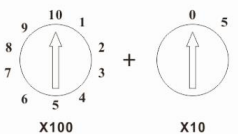
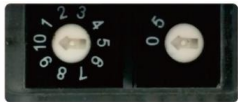

**Programmable Constant Current**

- Pre-set by factory.
- Adjusting it from the preset will alter the emergency runtime.

## !IMPORTANT SAFEGUARDS!

WHEN USING ELECTRICAL EQUIPMENT, BASIC SAFETY PRECAUTION SHOULD ALWAYS BE FOLLOWED, INCLUDING THE FOLLOWING

### Read And Follow All Safety Instruction

1. CAUTION- DO NOT MOUNT NEAR GAS OR ELECTRONIC HEATERS.
2. CAUTION- EQUIPMENT SHOULD BE MOUNTED IN LOCATIONS AND AT HEIGHTS WHERE IT WILL NOT BE SUBJECTED TO TAMPERING BY UNAUTHORIZED PERSONNEL.
3. CAUTION- THE USE OF ACCESSORY EQUIPMENT NOT RECOMMENDED BY THE MANUFACTURER MAY CAUSE AN UNSAFE CONDITION.
4. CAUTION- DO NOT USE THIS EQUIPMENT FOR OTHER THAN ITS INTENDED USE.
5. Use with grounded, UL Listed, damp location rated fixtures and case should be grounded.
6. The equipment is intended for ordinary locations and for permanent installation into one or more Listed luminaires.
7. Not for use in outdoor environments, heated air outlets, or hazardous locations.



**CAUTION: before installation, make certain the A.C. power is off.**

#### STEP1: INSTALLING THE EMERGENCY LED DRIVER

- > Test button and indicator light shall be installed where they can be seen depending on the application.
- > Turn off the AC power before installing.

#### STEP2: WIRING THE EMERGENCY DRIVER

- > The EMB and A.C. driver must be on the same branch circuit.
- > Select the appropriate wiring diagram to connect the emergency driver to the AC driver. For other diagrams, consult the manufacturer.
- > Using wire nuts to cover unused wires and make sure all connections are in accordance with the NEC and any local regulations.

#### STEP3: TESTING

- > After wiring is complete, check if the indicator light lights or not , which will indicate the battery's charging status.

### Installation Instruction

#### Step 1

Get the original driver.

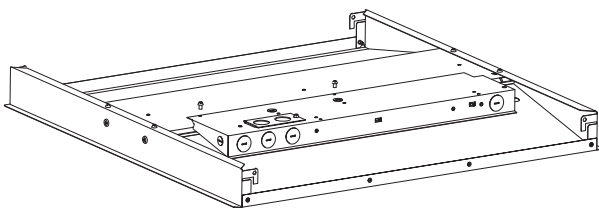

Remove the screws shown to take off the driver compartment.

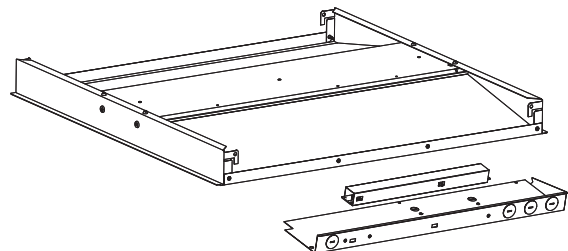

Detach the driver from the driver compartment.

Step 2

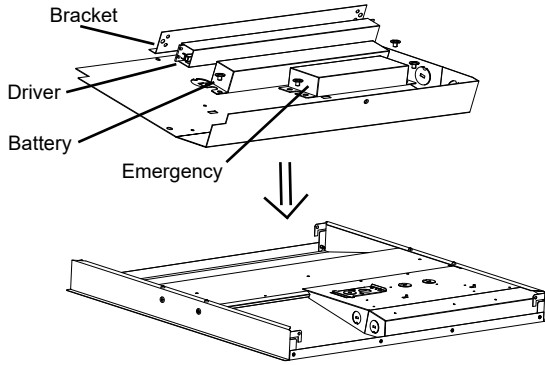

Test switch installation

Type 1 Mounted on reflector

Type 2 Mounted on wall

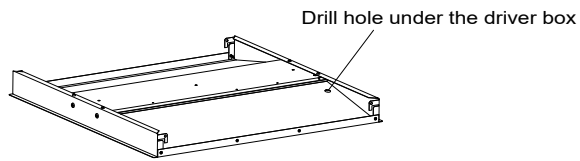
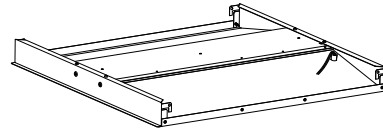

Attach the driver to the bracket using the included plastic push fasteners. Mount the driver and bracket to the larger driver compartment using the supplied screws. Next mount the battery and emergency driver to the larger driver compartment using the supplied screws. Make the wiring connections as shown in the wiring diagram. Attach the completed unit to the fixture. Install the test switch for your use case.

Wiring Diagram

