

INSTALLATION INSTRUCTIONS

INSTALL INSTRUCTIONS



WARNING: THIS PRODUCT MUST BE INSTALLED IN ACCORDANCE WITH THE APPLICABLE INSTALLATION CODE BY A PERSON FAMILIAR WITH THE CONSTRUCTION AND OPERATION OF THE PRODUCT AND THE HAZARDS INVOLVED

RISK OF SHOCK: DISCONNECT POWER BEFORE INSTALLATION

Risk of fire or electric shock - The electrical rating of this product is 120-277V, the installer must determine whether they have AC120V-277V at the luminaire before installation.

Risk of fire or electric shock - Retrofit kit installation requires knowledge of fluorescent lighting luminaires electrical systems. If not qualified, do not attempt installation. Contact a qualified electrician.

Risk of fire or electric shock. - Install this kit only in the luminaires that have the construction features and dimensions shown in the drawings.

Risk of fire or electric shock. - Do not use this kit in luminaires that employ shunted bi-pin lamp holders (found in fixtures that use instant start ballasts.)

Risk of fire or electric shock. - Luminaires wiring, ballasts, or other electrical parts may be damaged when drilling for installation of retrofit kit hardware. Check for enclosed wiring and components.

To prevent wiring damage or abrasion, do not expose wiring to edges of sheet metal or other sharp objects

IMPORTANT SAFETY INSTRUCTIONS

- Do not make or alter any open holes in an enclosure of wiring or electrical components during kit installation.
- Not for use with dimmers.
- The end retrofit luminaire has been modified and can no longer operate the originally intended lamp.
- Caution-Risk of Electric Shock-SUITABLE IN DAMP LOCATION.
- Risk of Electric shock-Do Not Use Where Directly Exposed To Water.
- This device is not intended for use with emergency exit fixtures or emergency exit lights.

REMOVING FLUORESCENT LAMP SYSTEM

- Disconnect power from fixture
- Remove fluorescent bulb
- Remove wiring compartment cover
- Cut all wires which are connected to the ballast and remove it.

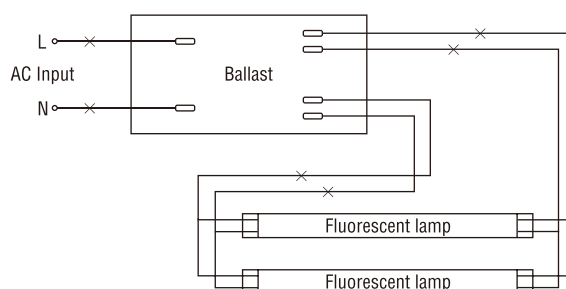
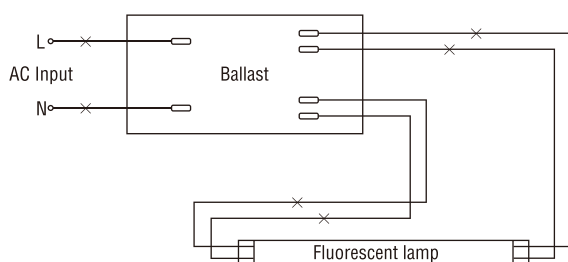

INSTALLATION INSTRUCTIONS

INSTALL INSTRUCTIONS

STOP

DO NOT install this product in a fixture that uses shunted lamp holders (found in all fixtures with instant start ballasts). Installing this product with shunted lamp holders will cause a short circuit condition in the lamp holder and create a fire or shock hazard. Before continuing, determine if the lamp holders currently installed in the fixture are shunted or non-shunted. If the current lamp holders are shunted, cut the wires away from the lamp holders and install non-shunted lamp holders, making new connections with the lead wires at terminals indicated here:

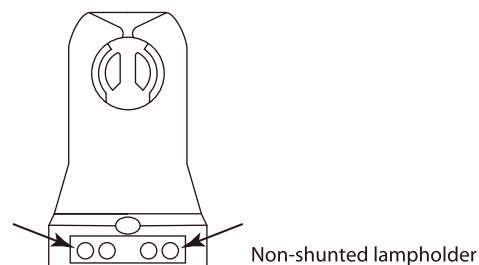

NOTE: If using existing non-shunted lamp holders, installer should not disconnect lead wires from the lamp holders and make new connections at terminals. Instead, cut lead wires away from lamp holder and make new connection to lead wires using approved connectors.

RETROFITTING FIXTURES WITH ONE LAMP

NOTE: Only one end of this LED tube received power. The "powered" end is indicated with a sticker on the tube itself. Before beginning installation, determine which end of the fixture will be the "powered" end and which end will be the "dead" end.

1. Make sure AC power to fixture is OFF
2. Make sure ground wire from AC supply is securely connected to ground screw inside fixture.
3. Connect black (live) and white (neutral) lead wires from the lamp holders on "powered" end to incoming AC supply black (LIVE) and white (NEUTRAL) wires with approved wire connectors. If only one lamp is being installed, proceed to step 4 below.

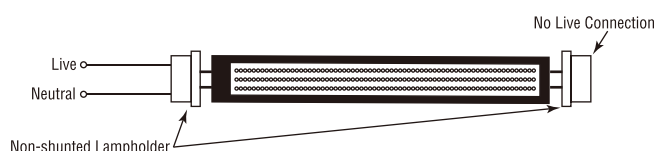

RETROFITTING FIXTURES WITH MULTIPLE LAMPS

After completing steps 1-3 above, connect terminals on the "powered" lamp holder for the first lamp matching terminals on "powered" lamp holder for a second with black (live) and white (neutral) wires, being sure to maintain polarity. Repeat this "daisy chain" connection for each additional lamp.

4. When all connections are complete, place appropriate connectors/wire nuts on the end of any unused wires.
5. Replace wiring compartment cover
6. Place sticker that is included with this product on wiring compartment cover or other conspicuous place on or inside the fixture. Sticker reads: " This fixture has been modified. The ballast has been removed. DO NOT install fluorescent lamps in this fixture"
7. Install LED tube(s), matching the end of the lamp that has the "L/N" sticker to the lamp holder that is connected to the Live and Neutral wires.
8. Re-connect power to fixture

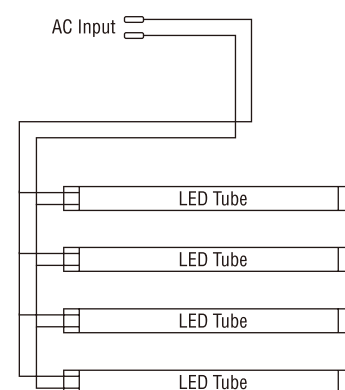

**The luminaire wiring has now been modified and will no longer operate fluorescent lamps
Do not use with dimmers · Suitable for damp locations .
This device is not intended for use with emergency exits.**